

Product introduction

Oversized silence check valve is flow-line designed according to hydrodynamics and the pressure loss is very little. The valve is installed at the outlet of the pump, and it closes before the fluid flow backward, so prevent water-hammering, water-hitting and destructive impact. So the valve can run quietly in the system. It is widely used in feeding/draining system, fire protection, heat supplying system and industry.

Main technical parameters

Nominal pressure: 1.0-2.5MPa

Nominal diameter: 300-1200mm

Service: water, oils, sea water, sewage

Working temperature: 0-80

Flanged end: GB/T17241.6 GB9113

Inspection and test: GB/T 13927 API 598

Typical installation diagram

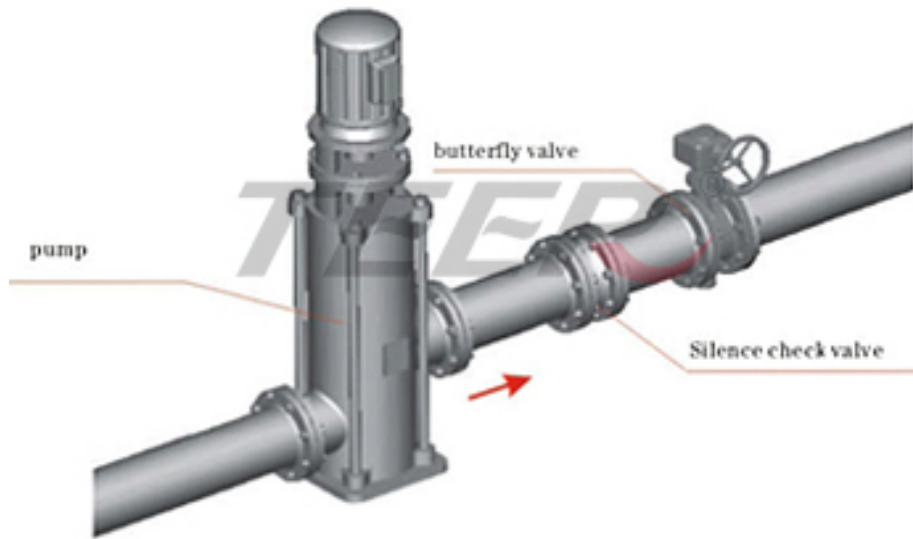

Material

part	body	disc	bearing	spring	Diversion shuttle	seat
material	GG25	ZQA19-4	ZQA19-4	SUS316	Gg25	ZQA19-4

Main dimensions unit:mm

DN	300	350	400	450	500	600	700	800	900	1000	1200
L	181	184	191	203	219	222	280	356	368	432	524

Copyright: 2006 (C) China Zhejiang Teer Valve Co., Ltd.

Dong-ou Industrial Zone, Wenzhou, Zhejiang, China, 325100

Int'l trade: Tel:(86)577-57999777 67995111 67995115 67995116 Fax:57999888 Local sales: Tel:57989999

Fax:57989988

[HTTP://www.chinateer.com](http://www.chinateer.com) E-mail: trade@chinateer.com